

Rotary Vane Pumps

PASCAL Series (dual stage)



2005SD, 2010SD, 2015SD und 2021SD

Pascal SD series dual stage rotary vane pumps are optimum for all non-corrosive vacuum applications. The range comprises for models with pumping speed between 5.4 and 20.7 m³/h.

Advantages:

- **No oil contamination at exhaust.** Minimum oil misting thanks to optimum design of the lubrication circuit.
- **System integration:** low footprint and volume, selection between vertical and horizontal inlet. Access to all „facilities“ (sight glass, gas ballast, etc.) at one side of the pump.
- **Optimum tightness:** suckback valve. All static seals are grooved O-rings.
- **Universal 1-phase or 3-phase motors for ww operation.**

Specifications:

		Units	2005SD	2010SD	2015SD	2021SD
Nominal pumping capacity (*)	50 Hz	m ³ /h	5.4	9.7	15	20.7
	60 Hz	cfm	3.8	6.8	10.6	14.6
Pneurop pumping capacity (*)	50 Hz	m ³ /h	4.8	8.5	12	15.5
	60 Hz	cfm	3.4	6	8.8	11.8
Final total pressure (*) (gas ballast closed)		mbar	2·10 ⁻³	2·10 ⁻³	2·10 ⁻³	2·10 ⁻³
Weight (max.)		kg (lbs)	25 (55)	26 (57.2)	27 (59.4)	28 (61.6)
Max nominal power rating	50/60 Hz	kW	0.45/0.55	0.45/0.55	0.45/0.55	0.45/0.55
Min. ambient temperature		°C (°F)	12 (54)	12 (54)	12 (54)	12 (54)
Max. ambient temperature		°C (°F)	45 (113)	45 (113)	45 (113)	45 (113)
Oil capacity		litres	0.83	0.95	0.95	0.98
Inlet flange		DN ISO-KF	25	25	25	25
Outlet flange		DN ISO-KF	25	25	25	25

(*) according to PNEUROP, with adixen mineral oil

Dimensions:

Filling hole 3/8" G

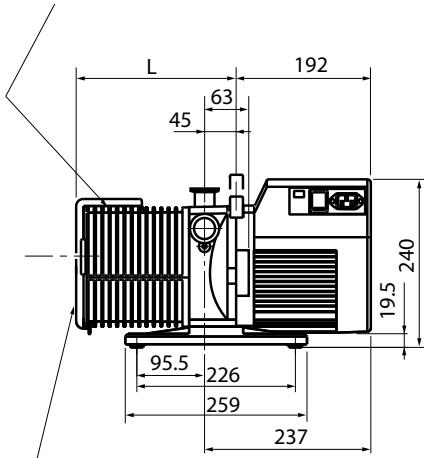

Drain 3/8" G

inlet NW25

exhaust NW25

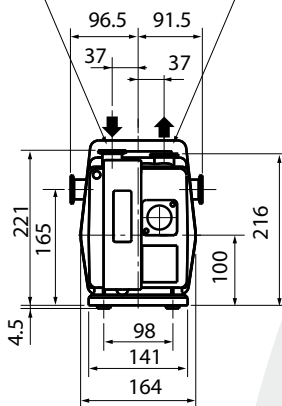

Pumping speed [m³/h]:

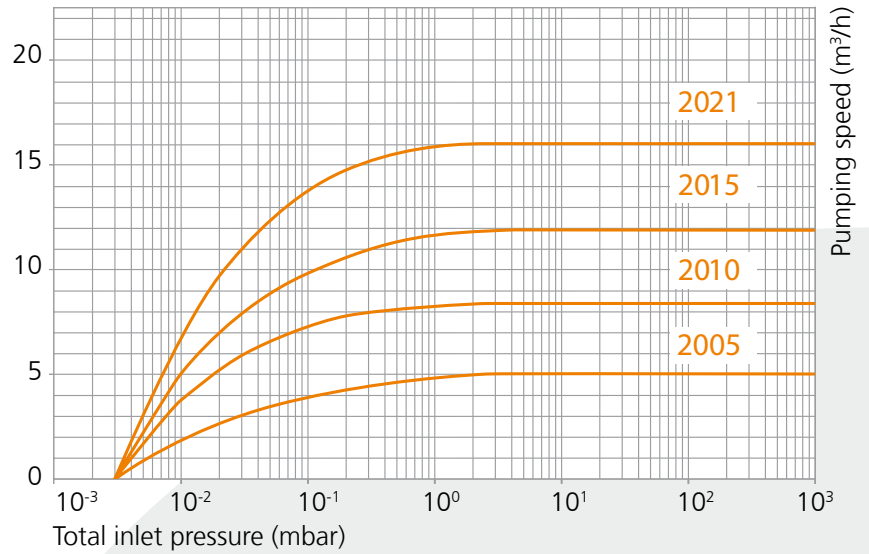

Maintenance and seal sets:

Model	Order No. Service kit	Order No. Seal kit	Order No. Shaft seal kit
2005SD	103902	103911	065875
2010SD	103903	103911	065875
2015SD	103904	103911	065875
2021SD	103905	103911	065875

Oil mist eliminator:

OME 25S

Replacement cartridges (5 off)

Order No. 104200

Order No. 068304



Customer benefits:

Effective retention of oil mist, especially when pumping down; prevents odour nuisance.

Lubricants:

A120

Pack size - 2 litres
Pack size - 5 x 2 litres
Pack size - 56 litres

Order No. 068099

Order No. 068844

Order No. 010991

Oil type:

Paraffin-based mineral oil

Application area:

General application areas
Non-corrosive gases

For further information please see:

www.adixen.co.uk