

Compact Dry Roughing Pumps

ACP series - oil-free, particle-free



ACP 28, ACP 28G, ACP 40 and ACP 40G

The ACP series incorporates the adixen multi-stage roots pump design. This design meets the highest requirements where clean vacuum really matters. There are many "dry" pumping concepts but only the multi-stage roots design provides outstanding performance for oil-free vacuum without particulate contamination.

Advantages:

- **Longest maintenance intervals on the market**
- **No particulate contamination - due to the frictionless design there are no wearing parts or seals in the path of the pumped gases.** This is the only way to generate particle-free vacuum.
- **No seals between rotor and stator - the amount of wearing parts is minimized.** This provides for optimum long-term stability of vacuum performance.
- **Adaptation of vacuum performance to process requirements** by integrated frequency converter.

Specifications:

	Units	ACP 28	ACP 28G	ACP 40	ACP 40G
Peak pumping speed	m ³ /h (CFM)	27 (16)	27 (16)	37 (22)	37 (22)
Ultimate pressure w/o purge (*)	mbar	3 · 10 ⁻²	3 · 10 ⁻²	3 · 10 ⁻²	3 · 10 ⁻²
Ultimate pressure with (...) sccm purge (*)	mbar (sccm)	NA	1 · 10 ⁻¹ (1650)	NA	1 · 10 ⁻¹ (1650)
Ultimate pressure with open gas ballast (*)	mbar	2 · 10 ⁻¹	NA	2 · 10 ⁻¹	NA
Maximum continuous inlet pressure	mbar	1013	1013	1013	1013
Input voltage (single phase)	V (Hz)	90 to 254 (50/60)		90 to 254 (50/60)	
Power consumption at ultimate pressure	W	700	700	700	700
Power consumption at atmosphere	W	1200	1200	1200	1200
Ambiant temperature	°C	12 to 40	12 to 40	12 to 40	12 to 40
Inlet port	DN ISO-KF	25	25	40	40
Exhaust port	DN ISO-KF	25	25	25	25
Tightness	mbar · l/s	5 · 10 ⁻⁷	5 · 10 ⁻⁷	5 · 10 ⁻⁷	5 · 10 ⁻⁷
Port for N2 purge		NA	R1/4" G	NA	R 1/4" G
Weight	kg	30	31	32	33

(*) typical values.

Dimensions (mm):

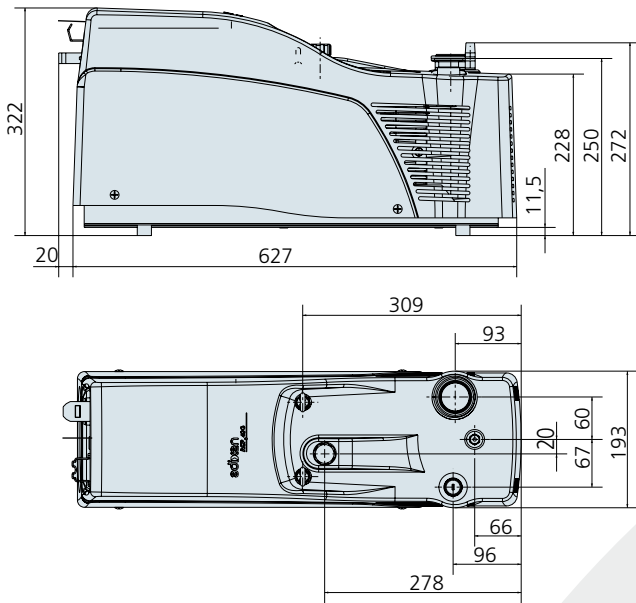

Pumping speed:

ACP 28 and ACP 28G

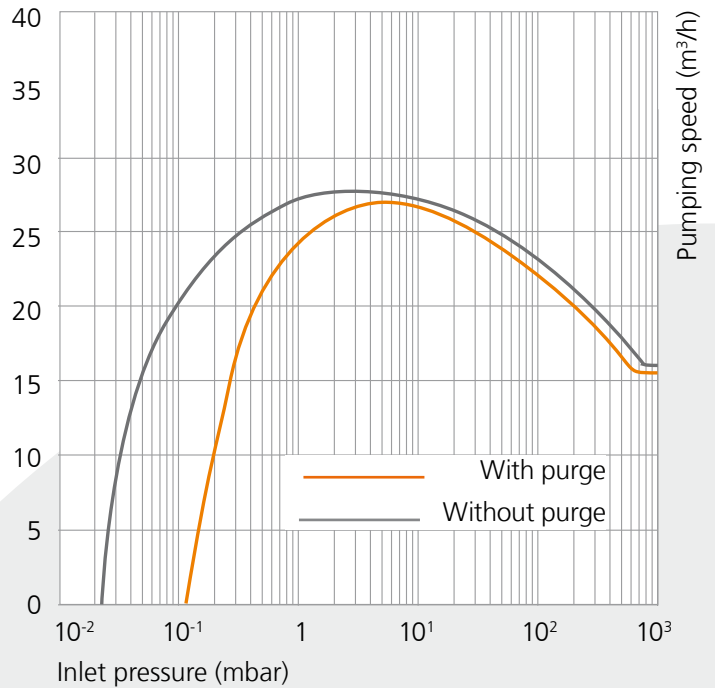

Noise reduction cover:

NRC 28/40

P/N 112637



Reduction of noise level at base pressure by 5 to 6 dBA.

Exhaust silencer:

ES 25S

P/N 109873



Significantly reduces noise level during pump down or permanent pump operation at high pressures.

Particle filter:



Protects the pump from external particles e.g. from glass breakage. Effective mesh size is 20 to 25 µm.

ACP 40 and ACP 40G

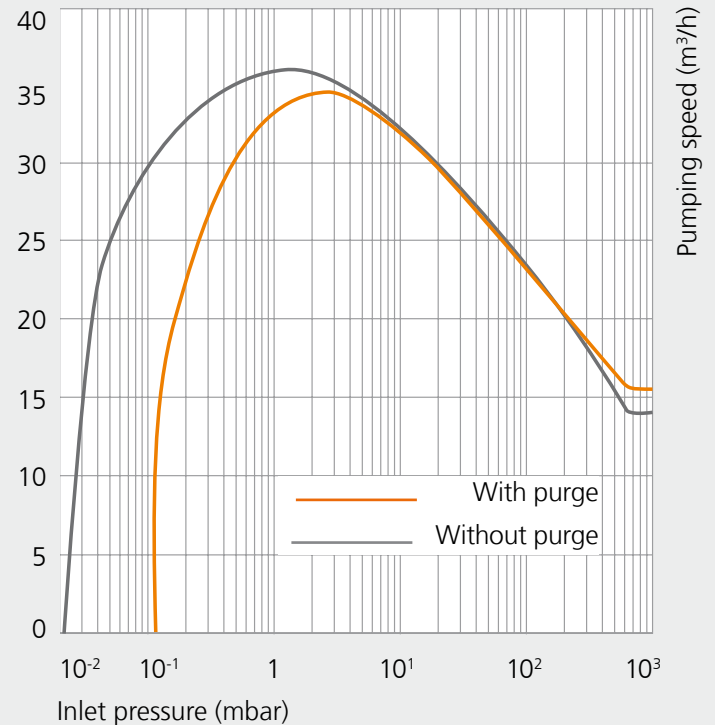

KF 25

P/N 111649

KF 40

P/N 111647

For further information please see:

<http://www.adixen.co.uk>